

Part 1

OPERATION OF INSTRUMENTS AND CONTROLS—

Chapter 1-2

Keys and Doors

- Keys
- Side doors
- Power windows
- Back door
- Hood
- Theft deterrent system
- Fuel tank cap
- Sport roof

Keys

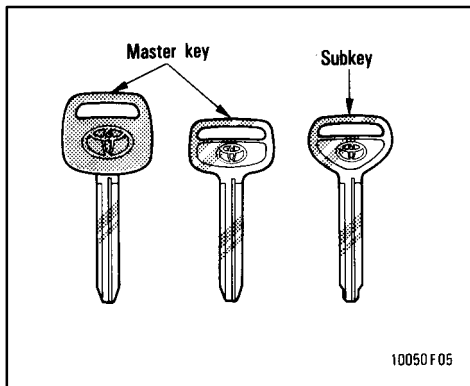

The master key works in every lock. The subkey will not work in the glovebox.

To protect things locked in the glovebox when you have your vehicle parked, leave the subkey with the attendant.

Since the side doors and back door can be locked without a key, you should always carry a spare master key in case you accidentally lock your keys inside the vehicle.

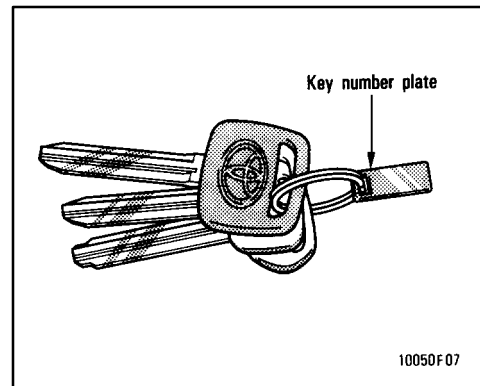

Keep the key number plate in a safe place such as your wallet, not in the vehicle.

If you should lose your keys or if you need additional keys, duplicates can be made by a Toyota dealer using the key number.

You should also put a copy of the key number with your important papers.

Side doors

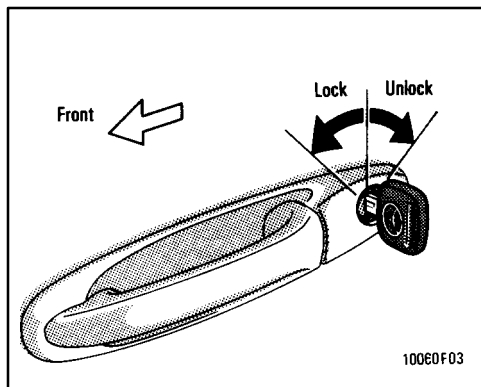

LOCKING WITH KEY

Turn the key toward the front of the vehicle to lock and towards the back to unlock.

Both doors locks and unlock simultaneously with either door. In the driver's door lock, turning the key once will unlock the driver's door and twice in succession will unlock both doors simultaneously.

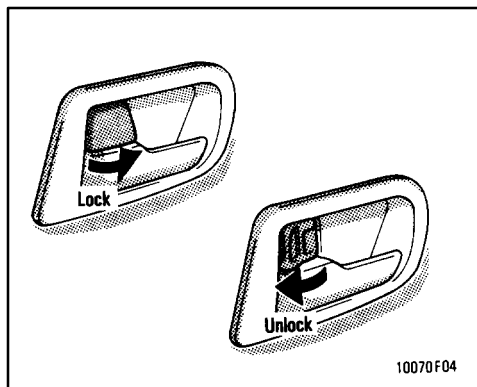

LOCKING WITH INSIDE LOCK KNOB

Turn the lock knob forward to lock and backward to unlock the door.

Closing the door with the lock knob in the lock position will also lock the door. Be careful not to lock your keys in the vehicle. The door cannot be locked if you leave the key in the ignition switch.

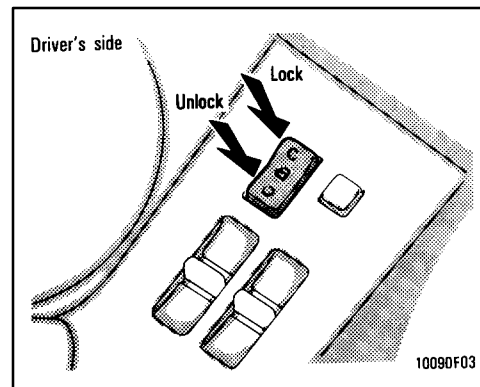

LOCKING WITH POWER DOOR LOCK SWITCH

To lock both of the doors simultaneously, push the power door lock switch on the LOCK side. Pushing on the UNLOCK side will unlock them.

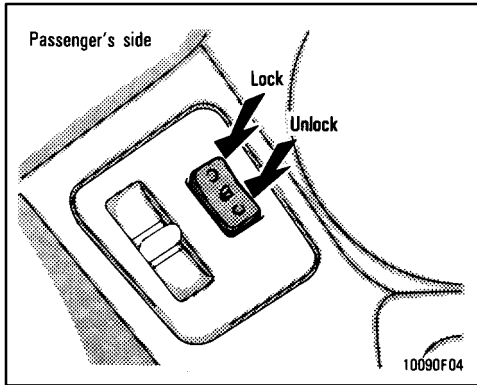

! CAUTION

Before driving, be sure that the doors are closed and locked, especially when small children are in the vehicle. Along with the proper use of seat belts, locking the doors helps prevent the driver and passengers from being thrown out from the vehicle during an accident. It also helps prevent the doors from being opened unintentionally.

Power windows

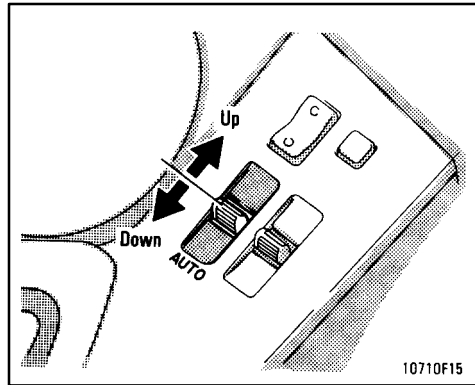

The windows can be operated with the switch on each side door.

The power windows work when the ignition switch is in the "ON" position. However, if both side doors are closed, they work for 60 seconds even after the ignition switch is turned off. They stop working when either side door is opened.

OPERATING THE DRIVER'S WINDOW

Use the switch on the driver's door.

Normal operation: The window moves as long as you hold the switch.

To open: Lightly pull down the switch.

To close: Push up the switch.

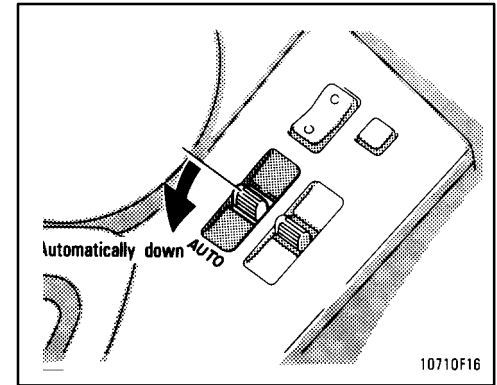

Automatic operation (to open only):

Pull the switch completely down and then release it. The window will fully open. To stop the window partway, lightly push the switch up and then release it.

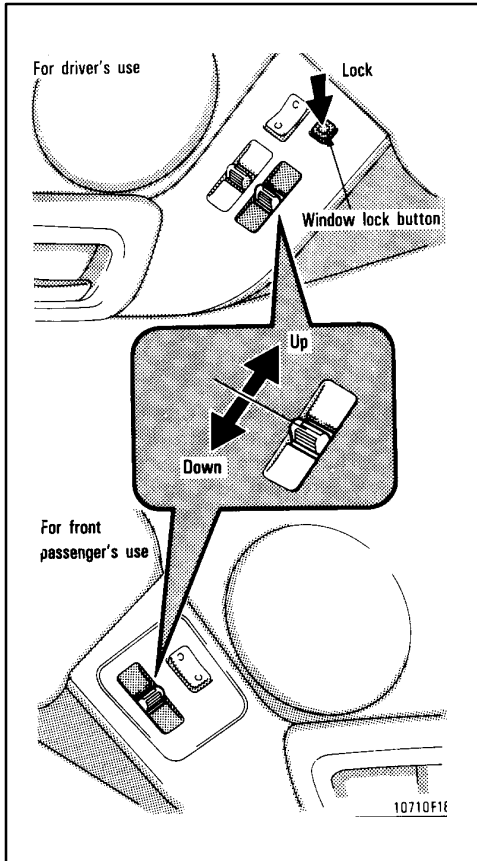

OPERATING THE PASSENGER'S WINDOW

Use the switch on the passenger's door. The driver's door also has a switch that controls the passenger's window.

The window moves as long as you hold the switch.

To open: Pull down the switch.

To close: Push up the switch.

If you push in the window lock button on the driver's door, the passenger's window cannot be operated.



To avoid serious personal injury, you must do the following.

- Always make sure the head, hands and other parts of the body of all occupants are kept completely inside the vehicle before you close the power windows. If someone's neck, head or hands gets caught in a closing window, it could result in a serious injury. When anyone closes the power windows, be sure that they operate the windows safely.
- When small children are in the vehicle, never let them use the power window switches without supervision. Use the window lock button to prevent them from making unexpected use of the switches.
- Never leave small children alone in the vehicle, especially with the ignition key still inserted. They could use the power window switches and get trapped in a window. Unattended children can become involved in serious accidents.

Back door--

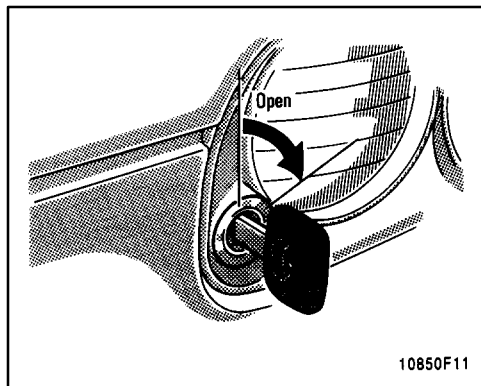

To open the back door from the outside, insert the key and turn it clockwise.

See "Luggage storage precautions" in Part 2 for precautions to observe in loading luggage.

To close the back door, lower it and press down on it. After closing the back door, try pulling it up to make sure it is securely closed.



Keep the back door closed while driving. This not only keeps the luggage from being thrown out but also prevents exhaust gases from entering the vehicle.

--Lock release lever

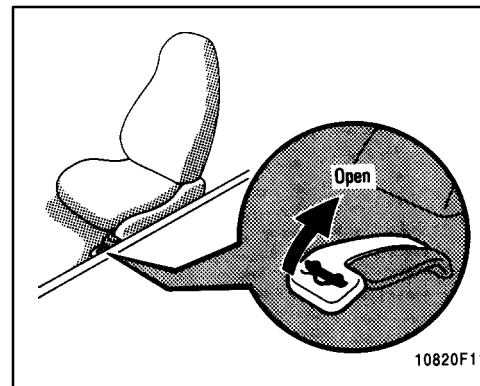

To open the back door from the driver's seat, pull up on the lock release lever.

Hood

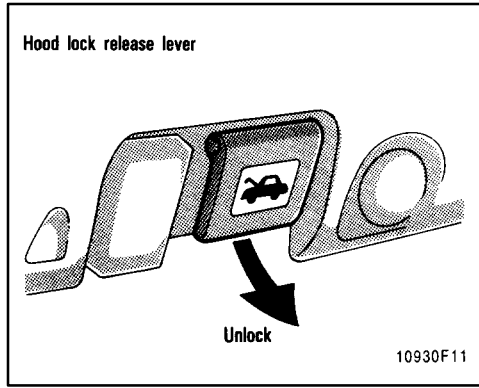

- To open the hood, do the following.
1. Pull the hood lock release lever. The hood will spring up slightly.

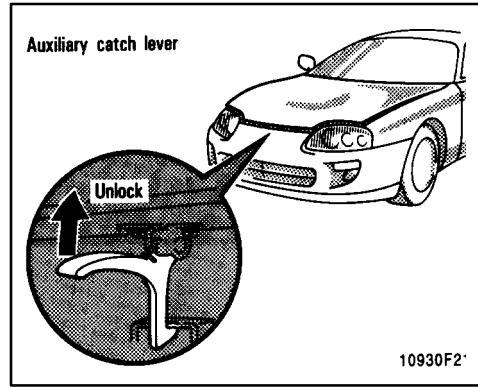

2. In front of the vehicle, pull up on the auxiliary catch lever and lift the hood.

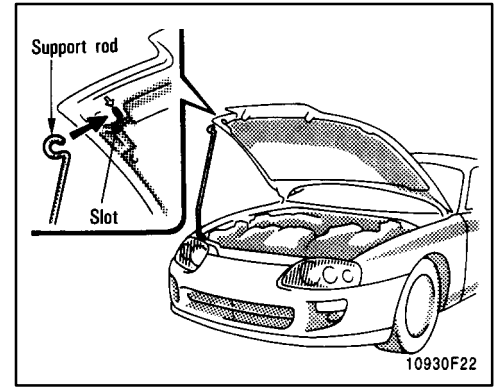

3. Hold the hood open by inserting the support rod into the slot.

Before closing the hood, check to see that you have not forgotten any tools, rags, etc. and return the support rod to its clip—this prevents rattles.



After inserting the rod, make sure it supports the hood security.

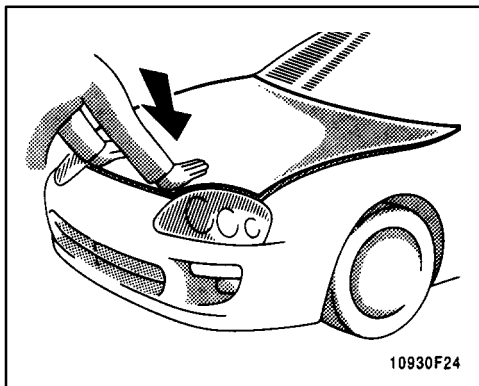
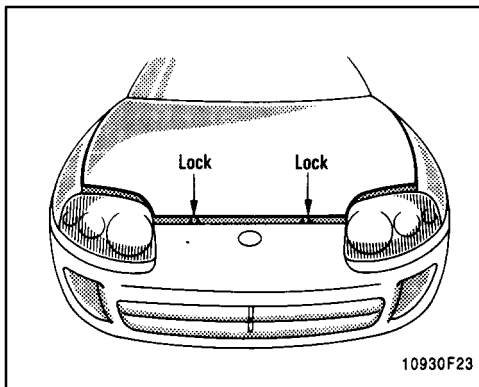

Your Supra has two hood locks at the front edge of the hood.

To close the hood, lower the hood until it is about 30 cm (12 in.) above the engine compartment and release it. If the hood is still not fully closed, press down on it above the two hood locks. Make sure the hood is locked securely.

If you notice while driving that the hood is not locked, stop the vehicle at once and close the hood.



When closing the hood, be careful not to get your hands caught between the hood and the vehicle body.

NOTICE

Do not press hard on the hood except above the hood locks, or you may deform the hood.

Theft deterrent system

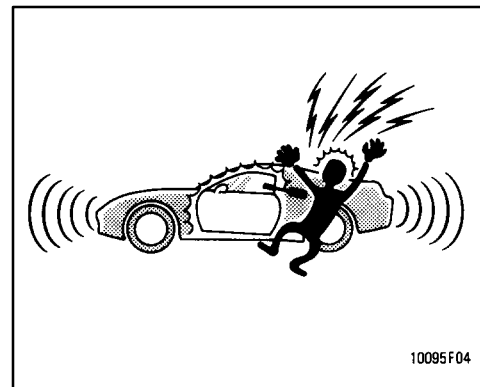

To deter the vehicle theft, the system is designed to give an alarm and keep the engine from being started if any of the side doors, back door or hood is forcibly unlocked or the battery terminal is disconnected and then reconnected when the vehicle is locked.

The alarm blows the horn intermittently and flashes the headlights, tail lights and other exterior lights. The engine cannot be started because the starter circuit will be cut.

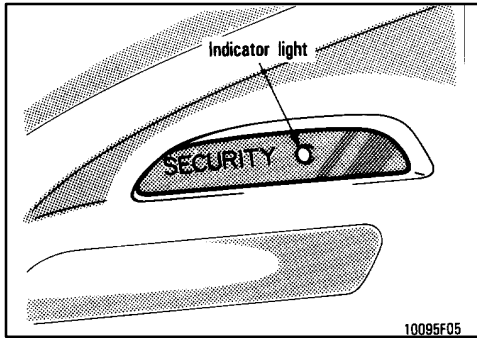

SETTING THE SYSTEM

1. Turn the ignition key to the “LOCK” position and remove it.
2. Have all passengers get out of the vehicle.
3. Close and lock all the side doors, back door and hood.

The indicator light will come on when all the side doors, back door and hood are closed and locked.

As the side doors are locked, the system will give you a preparation time of 30 seconds before the setting, during which the side doors, back door and hood may be opened to prepare for the setting.

Be careful not to use the key when opening any side door. This will cancel the system.

4. After making sure the indicator light starts flashing, you may leave the vehicle.

The system will automatically be set after the preparation time passes. The indicator light will flash to show the system is set. If any of the side doors, back door or hood is open at that time, the setting is interrupted until it is closed and locked.

Never leave anyone in the vehicle when you set the system, because unlocking from the inside will activate the system.

WHEN THE SYSTEM IS SET Activating the system

The system will give the alarm and cut the starter circuit under the following conditions:

- If any of the side doors, back door or hood is unlocked without using the key.
- If the battery terminal is disconnected and then reconnected

After one minute, the alarm will automatically stop with the starter circuit cut kept on.

Reactivating the alarm

Once set, the system automatically resets the alarm each time all the side doors, back door and hood are closed after the alarm stops.

The alarm will be activated again under the following conditions:

- If any of the side doors, back door or hood is opened
- If the battery terminal is disconnected and then reconnected

Stopping the alarm

Turn the ignition key from the “LOCK” to “ACC” position. The alarm will be stopped with the starter circuit cut kept on. Stopping the alarm in this manner will keep the alarm from being reactivated when any of the side doors, back door or hood is opened.

Interrupting the setting

When the system set, the back door can be opened by using the key without setting off the system. While the back door is open, the setting is interrupted and the side doors and hood may be opened in addition. However, when the battery terminal is disconnected and then reconnected, the system is activated.

Close and lock the side doors and hood, and the system will automatically be reset after two seconds when the back door is closed with the key removed.

CANCELLING THE SYSTEM

Unlock either side door with the key.

This cancels the system completely and the starter circuit cut will be cancelled at once.

INDICATOR LIGHT

The indicator light gives the following three indications.

FLASHING—The system is set. You need the key to open the side doors, back door and hood.

ON—The system will automatically be set when the time comes. The side doors, back door and hood may be opened without a key.

OFF—The system is inactive. You may open any door, trunk and hood.

TESTING THE SYSTEM

1. Open the windows
2. Set the system as described above. The side doors should be locked with the key. Be sure to wait until the indicator light starts flashing.
3. Unlock either side door from the inside. The system should activate the alarm
4. Cancel the system by unlocking either side doors with the key.
5. Repeat this operation for the other side doors, back door and hood. When testing on the hood, also check that the system is activated when the battery terminal is disconnected and then reconnected.

If the system does not work properly, have it checked by your Toyota dealer.

Fuel tank cap

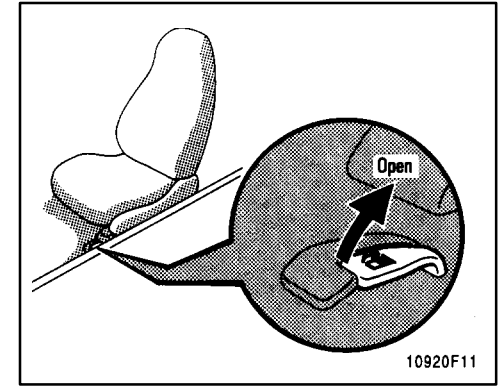

1. To open the fuel filler door, pull the lever up.



- Do not smoke, cause sparks or allow open flames when refuelling. The fumes are flammable.
- When opening the cap, do not remove the cap quickly. In hot weather, fuel under pressure could cause injury by spraying out of the filler neck if the cap is suddenly removed.

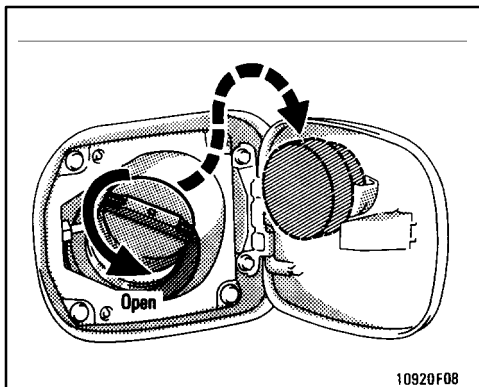

- To remove the fuel tank cap, turn the cap slowly counterclockwise, then pause slightly before removing it. After removing the cap, hang it on the cap hanger.

It is not unusual to hear a slight swoosh when the cap is opened. When installing, turn the cap clockwise till you hear a click.



CAUTION

- Make sure the cap is tightened securely to prevent fuel spillage in case of an accident.
- Use only a genuine Toyota fuel tank cap for replacement. It has a built in check valve to reduce fuel tank vacuum.

Sport roof-- --Detaching from vehicle

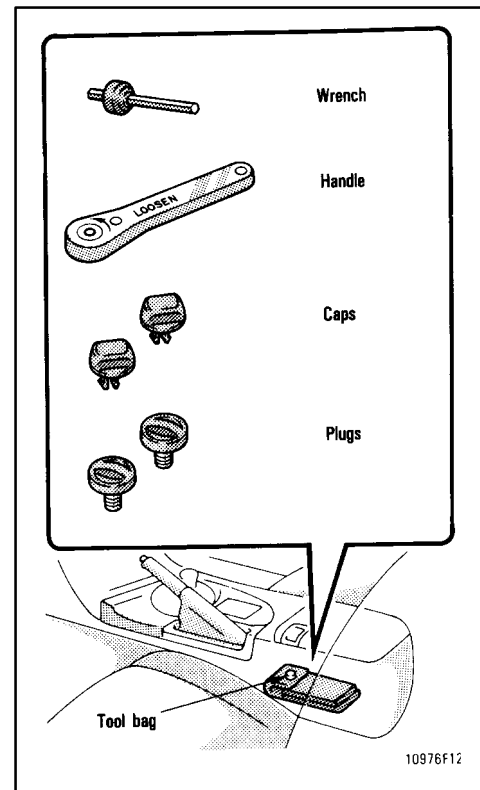

1. Get the tool bag out of the console box.

In the tool bag, you will find a special kit consisting of:

- Wrench and handle
 - For turning the center lock and the front and rear bolts
- Caps
 - For covering the front bolts
- Plugs
 - For stopping up the rear holes

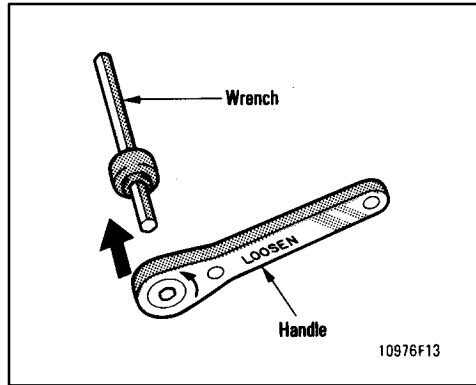

2. Face the “LOOSEN” side of the handle toward you and insert the wrench into the handle.

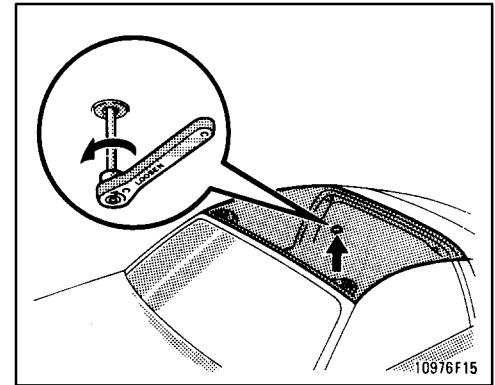

3. Unlock the center lock by inserting the wrench and turning it a 1/4 turn counterclockwise.

Before detaching the sport roof from the vehicle, fully open both of the side doors and windows, and clear the seats.

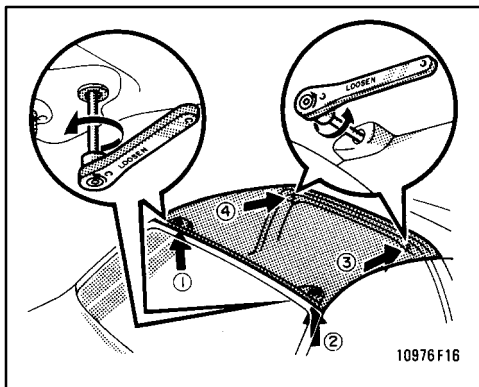

4. Loosen the bolts in the order shown by turning the wrench counterclockwise. Then lift up the front edge of the sport roof and lift off the roof forward.



CAUTION

Be careful not to get your hands or fingers caught between the sport roof and the vehicle body when detaching the roof.

NOTICE

Take care not to hit the sport roof against the vehicle body to avoid damage to the roof when detaching the roof.

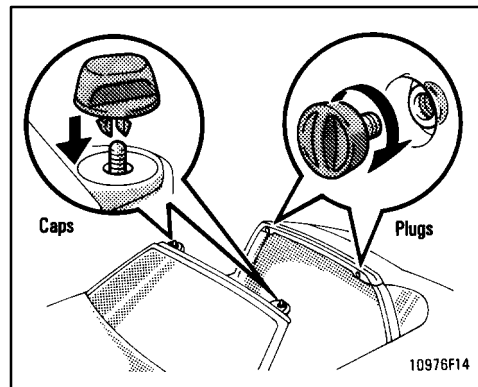

5. After removing the roof, put the caps on the front bolts and insert the plugs into the rear holes



CAUTION

- Do not stick your head, arms or any objects out of the opening while the vehicle is moving.
- Never attempt to remove the roof while driving.
- Do not sit on top of the vehicle around the opening.

--Stowing in luggage compartment

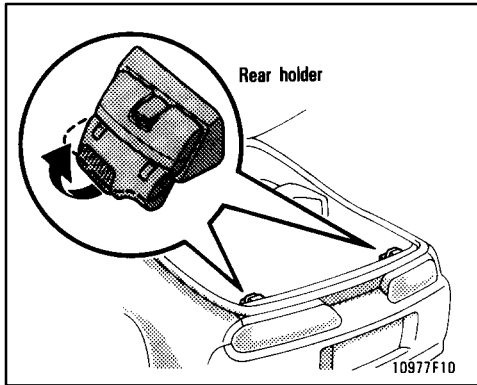

1. Open the back door and set up the rear holders as shown above.

Before stowing the roof in the luggage compartment, be sure to remove the luggage cover. (See "Luggage cover" in Chapter 1-8.)

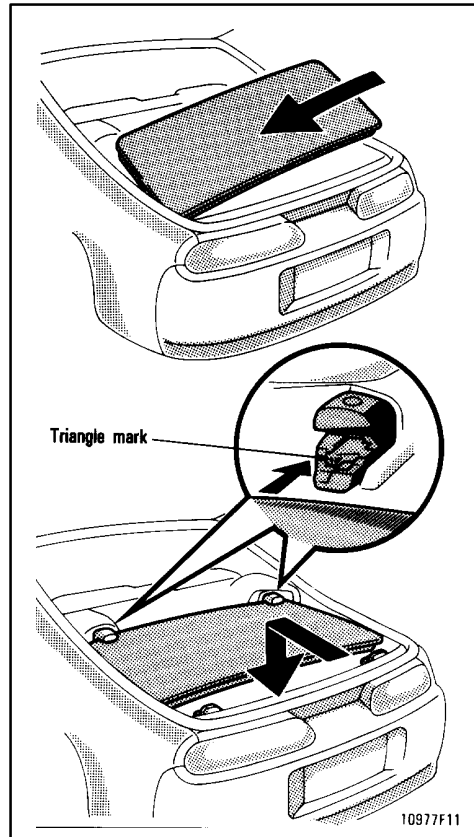

2. Put in the roof from the left side as shown. Then insert the front edge of the roof in the front holders, and engage the rear edge with the rear holders.

Put the front edge on the triangle marks of the front holders.

To engage the rear edge of the roof with the rear holders, put the rear edge on the holders while pushing the front edge fully forward against the front holders.



To minimize the risk of personal injury, make sure all four corners of the roof are securely locked in the holders after installation.

NOTICE

To avoid damage the roof panel, do not press on the center of the stowed roof panel and do not put anything on the stowed roof panel.

--Reinstalling on vehicle

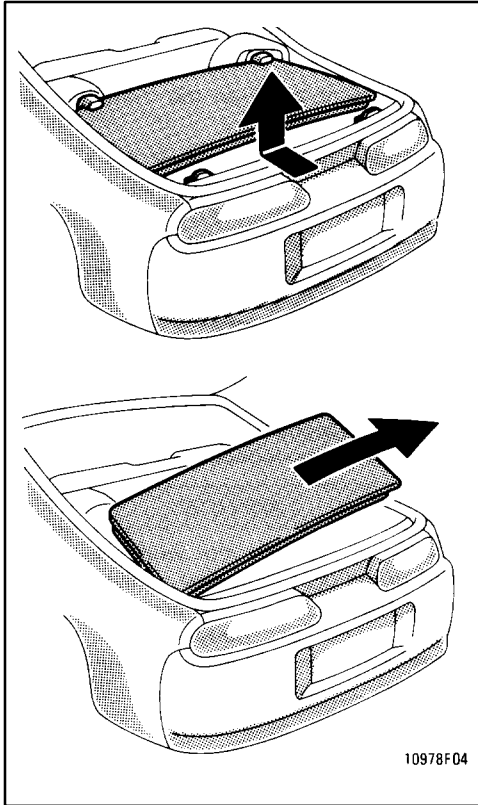

1. Lift up the rear edge while pushing the roof fully forward, then pull the front edge out of the holders. Remove the roof from the right side as shown.

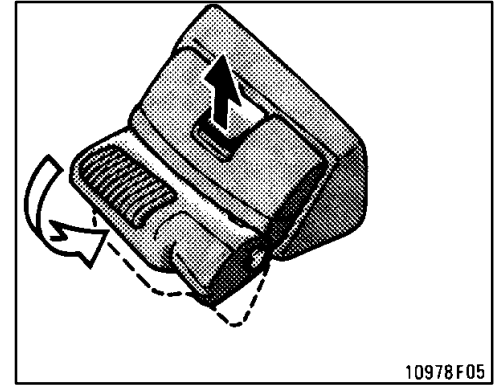

After removing the roof, put back the rear holders by pulling up the lock release knob.

NOTICE

Do not operate the knob until the roof has been removed.

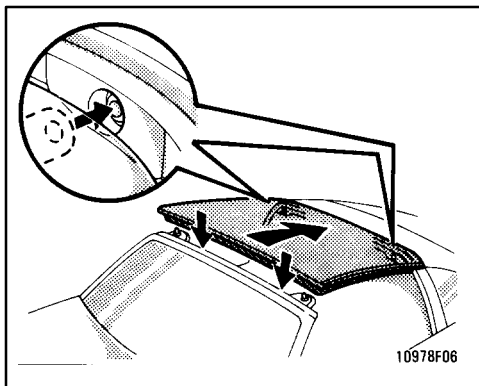

2. Place the rear edge on first and then the front edge.

Before installation, be sure to take the caps and plugs off.



To minimize the risk of personal injury, make sure all four corners are securely fixed on the brackets after installation.

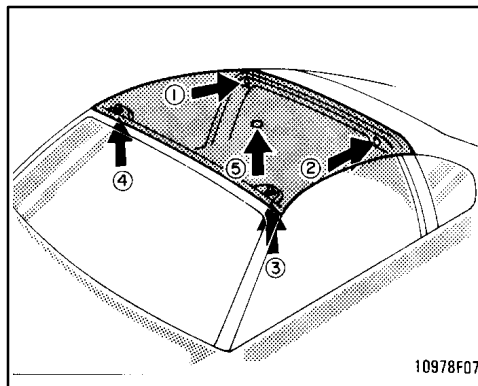

3. Tighten the bolts and lock the center lock in the order shown. (See “-Detaching from vehicle” for details.)

Note that all five connections need to be tight to secure the sport roof.

Reverse the wrench handle so the “TIGHTEN” side faces toward you and turn it clockwise.

Check that the roof is correctly installed by lightly trying to move the roof.

Put the wrench, handle, caps and plugs back in the tool bag in the console box.



CAUTION

Make sure to tighten all four bolts and to lock the center lock when installing the sport roof.

